

Abmessungen in mm

Type	A	AB	AC	B	BB	C	CA	D	DB	E	F	G	GD	H	HD	IPE	K	L
56	90	110	120	71	91	36	108	9	M3x7	20	3	7,2	3	56	156	1xM16x1,5	8,8	235
63	100	120	130	80	105	40	123	11	M4x8	23	4	8,5	4	63	173	1xM16x1,5	10	266
71	112	132	145	90	116	45	125	14	M5x10	30	5	11	5	71	188	1xM20x1,5	10	290
80	125	160	165	100	126	50	146	19	M6x12	40	6	15,5	6	80	217	1xM20x1,5	10	336
90S	140	175	185	100	133	56	146	24	M8x16	50	8	20	7	90	235	1xM20x1,5	10	355
90L	140	175	185	125	155	56	149	24	M8x16	50	8	20	7	90	235	1xM20x1,5	10	380
100L	160	196	205	140	174	63	170	28	M10x20	60	8	24	7	100	252	2xM20x1,5	12	433
112M	190	220	230	140	177	70	205	28	M10x20	60	8	24	7	112	292	2xM25x1,5	12	464
132S	216	252	270	140	177	89	223	38	M12x24	80	10	33	8	132	325	2xM25x1,5	12	532
132M	216	252	270	178	224	89	223	38	M12x24	80	10	33	8	132	325	2xM25x1,5	12	570

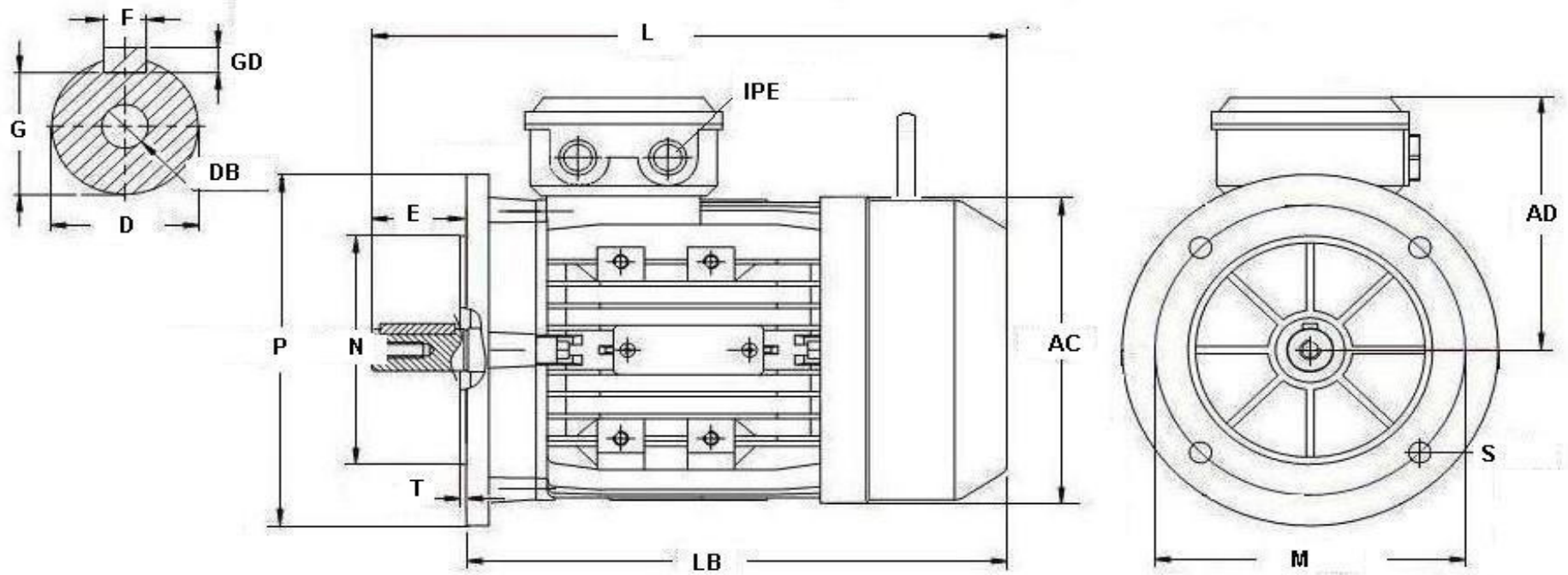

Abmessungen in mm

Type	AC	AD	D	DB	E	F	G	GD	IPE	L	LB	M	N	P	S	T
56	120	100	9	M3x7	20	3	7,2	3	1xM16x1,5	235	215	100	80	120	4x7	3,0
63	130	110	11	M4x8	23	4	8,5	4	1xM16x1,5	266	243	115	95	140	4x10	3,0
71	145	117	14	M5x10	30	5	11	5	1xM20x1,5	290	260	130	110	160	4x10	3,5
80	165	137	19	M6x12	40	6	15,5	6	1xM20x1,5	336	296	165	130	200	4x12	3,5
90S	185	145	24	M8x16	50	8	20	7	1xM20x1,5	355	305	165	130	200	4x12	3,5
90L	185	145	24	M8x16	50	8	20	7	1xM20x1,5	380	330	165	130	200	4x12	3,5
100L	205	152	28	M10x20	60	8	24	7	2xM20x1,5	433	373	215	180	250	4x12	4,0
112M	230	180	28	M10x20	60	8	24	7	2xM25x1,5	464	404	215	180	250	4x12	4,0
132S	270	193	38	M12x24	80	10	33	8	2xM25x1,5	532	452	265	230	300	4x12	4,0
132M	270	193	38	M12x24	80	10	33	8	2xM25x1,5	570	490	265	230	300	4x12	4,0

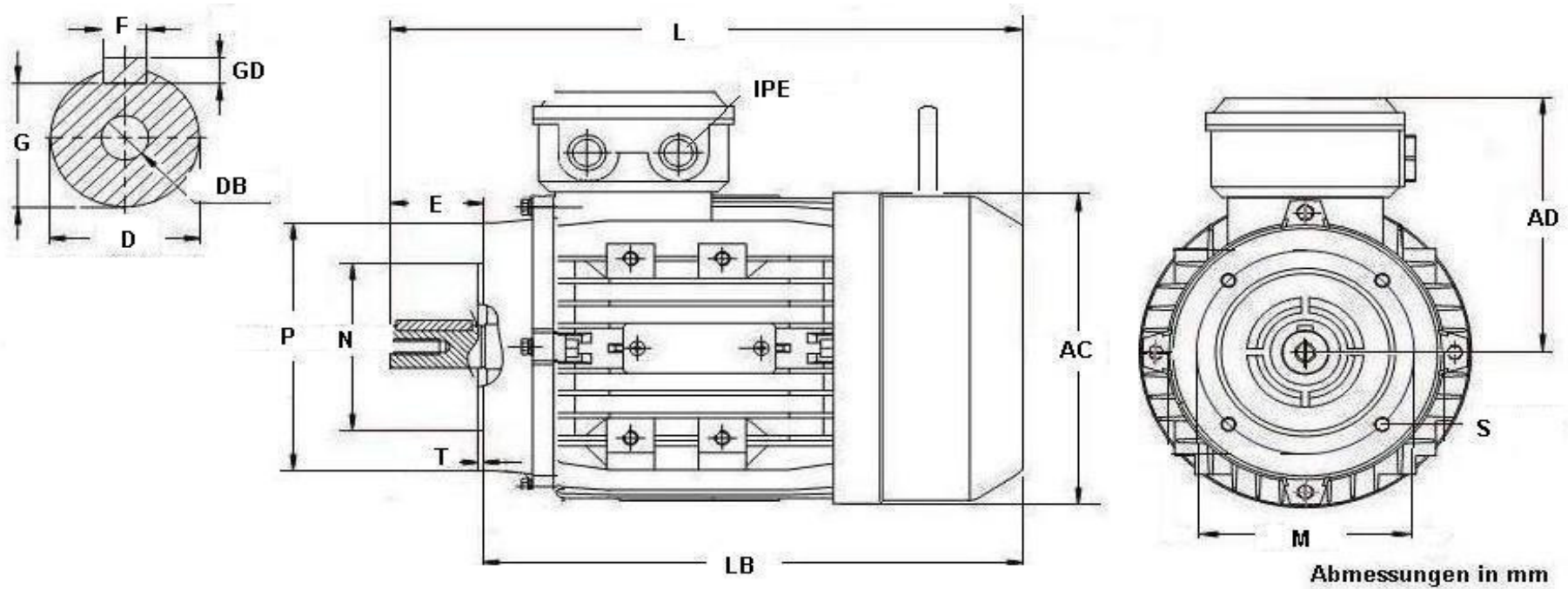

Type	AC	AD	D	DB	E	F	G	GD	IPE	L	LB	M	N	P	S	T
56	120	100	9	M3x7	20	3	7,2	3	1xM16x1,5	235	215	65	50	80	4xM5	2,5
63	130	110	11	M4x8	23	4	8,5	4	1xM16x1,5	266	243	75	60	90	4xM5	2,5
71	145	117	14	M5x10	30	5	11	5	1xM20x1,5	290	260	85	70	105	4xM6	2,5
80	165	137	19	M6x12	40	6	15,5	6	1xM20x1,5	336	296	100	80	120	4xM6	3,0
90S	185	145	24	M8x16	50	8	20	7	1xM20x1,5	355	305	115	95	140	4xM8	3,0
90L	185	145	24	M8x16	50	8	20	7	1xM20x1,5	380	330	115	95	140	4xM8	3,0
100L	205	152	28	M10x20	60	8	24	7	2xM20x1,5	433	373	130	110	160	4xM8	3,5
112M	230	180	28	M10x20	60	8	24	7	2xM25x1,5	464	404	130	110	160	4xM8	3,5
132S	270	193	38	M12x24	80	10	33	8	2xM25x1,5	532	452	165	130	200	4xM10	3,5
132M	270	193	38	M12x24	80	10	33	8	2xM25x1,5	570	490	165	130	200	4xM10	3,5

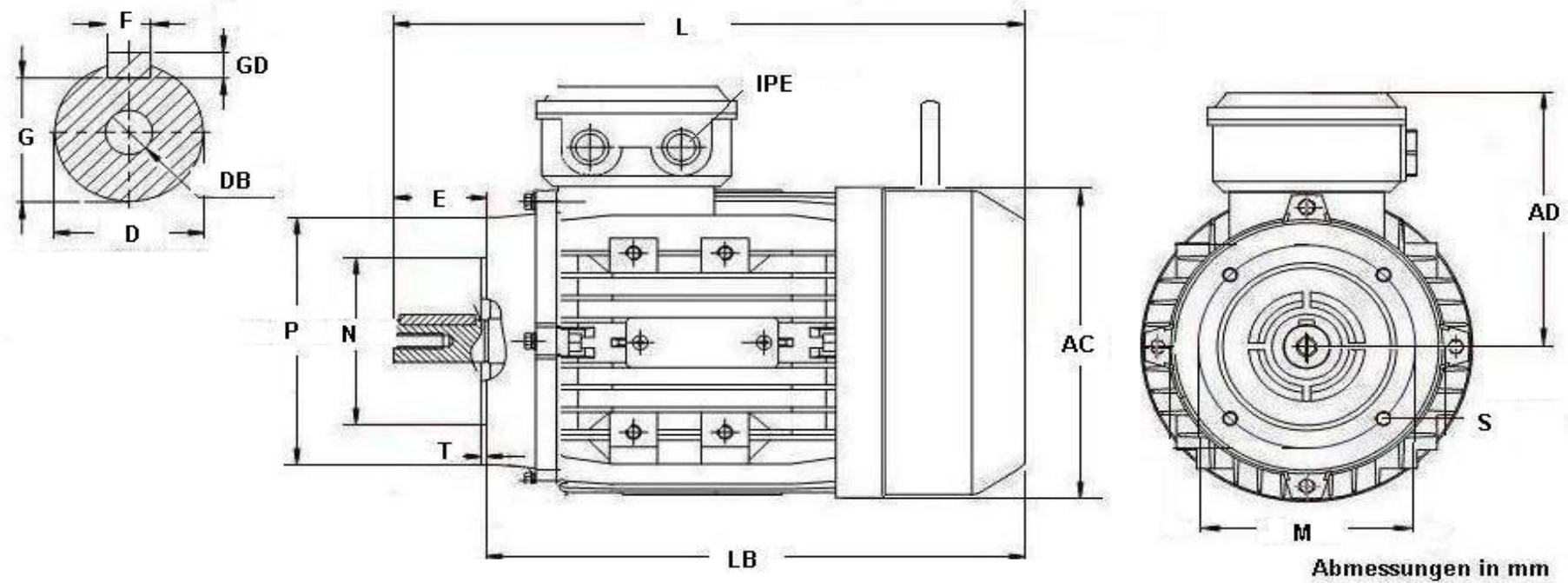

Abmessungen in mm

Type	AC	AD	D	DB	E	F	G	GD	IPE	L	LB	M	N	P	S	T
63	130	110	11	M4x8	23	4	8,5	4	1xM16x1,5	266	243	100	80	120	4xM6	3,0
71	145	117	14	M5x10	30	5	11	5	1xM20x1,5	290	260	115	95	140	4xM8	3,0
80	165	137	19	M6x12	40	6	15,5	6	1xM20x1,5	336	296	130	110	160	4xM8	3,5
90S	185	145	24	M8x16	50	8	20	7	1xM20x1,5	355	305	130	110	160	4xM8	3,5
90L	185	145	24	M8x16	50	8	20	7	1xM20x1,5	380	330	130	110	160	4xM8	3,5
100L	205	152	28	M10x20	60	8	24	7	2xM20x1,5	433	373	165	130	200	4xM10	3,5
112M	230	180	28	M10x20	60	8	24	7	2xM25x1,5	464	404	165	130	200	4xM10	3,5
132S	270	193	38	M12x24	80	10	33	8	2xM25x1,5	532	452	215	180	250	4xM10	4,0
132M	270	193	38	M12x24	80	10	33	8	2xM25x1,5	570	490	215	180	250	4xM10	4,0

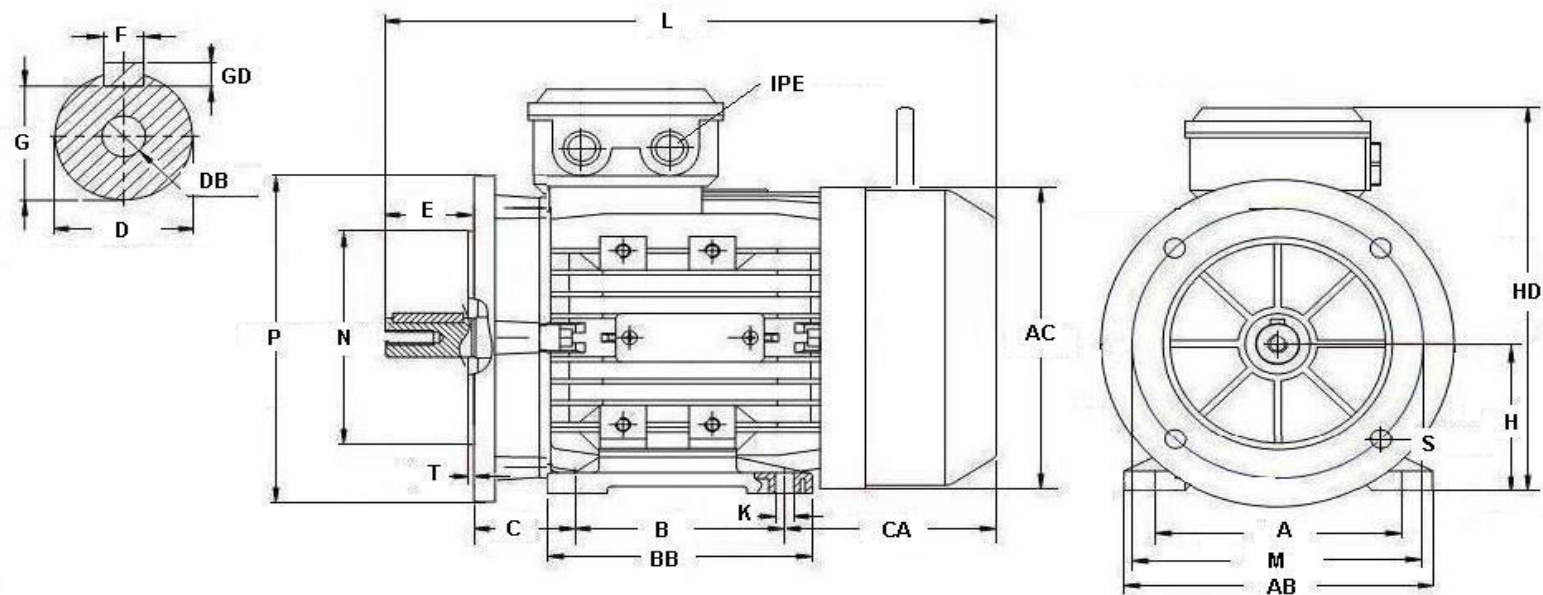

Abmessungen in mm

Type	A	AB	AC	B	BB	C	CA	D	DB	E	F	G	GD	H	HD	IPE	K	L	M	N	P	S	T
56	90	110	120	71	91	36	108	9	M3x7	20	3	7,2	3	56	156	1xM16x1,5	8,8	235	100	80	120	4x7	3,0
63	100	120	130	80	105	40	123	11	M4x8	23	4	8,5	4	63	173	1xM16x1,5	10	266	115	95	140	4x10	3,0
71	112	132	145	90	116	45	125	14	M5x10	30	5	11	5	71	188	1xM20x1,5	10	290	130	110	160	4x10	3,5
80	125	160	165	100	126	50	146	19	M6x12	40	6	15,5	6	80	217	1xM20x1,5	10	336	165	130	200	4x12	3,5
90S	140	175	185	100	133	56	146	24	M8x16	50	8	20	7	90	235	1xM20x1,5	10	355	165	130	200	4x12	3,5
90L	140	175	185	125	155	56	149	24	M8x16	50	8	20	7	90	235	1xM20x1,5	10	380	165	130	200	4x12	3,5
100L	160	196	205	140	174	63	170	28	M10x20	60	8	24	7	100	252	2xM20x1,5	12	433	215	180	250	4x12	4,0
112M	190	220	230	140	177	70	205	28	M10x20	60	8	24	7	112	292	2xM25x1,5	12	464	215	180	250	4x12	4,0
132S	216	252	270	140	177	89	223	38	M12x24	80	10	33	8	132	325	2xM25x1,5	12	532	265	230	300	4x12	4,0
132M	216	252	270	178	224	89	223	38	M12x24	80	10	33	8	132	325	2xM25x1,5	12	570	265	230	300	4x12	4,0